

DATALOGIC

Heron™

D150 EAS READERS

QUICK REFERENCE

GUIDA RAPIDA

GUIDE RAPIDE

KURZANLEITUNG

GUÍA RÁPIDA



820001391 (Rev. B)

USING HERON™ SERIES READERS



UK

Heron™ guns automatically scan barcodes **at a distance**. Simply aim and pull the trigger. Code scanning is performed along the center of the light bar emitted from the reading window. This bar must cover the entire code.

Successful scanning is obtained by tilting the scanner with respect to the barcode to avoid direct reflections which impair the reading performance, see the figure above.

Successful reading is signaled by an audible tone plus a good-read green spot.

By correctly inserting the reader into its stand, it is immediately ready to read automatically any code present in its reading area without pressing the trigger. Furthermore, a green aiming light is continuously emitted to facilitate the positioning of the barcode to be read, see the figure above. To guarantee single code reading, same code consecutive reading requires the code to be removed from the reading area (no decoding) before the reader will accept the same code.

I

Con le pistole Heron™ la lettura dei codici a barre avviene a **distanza**: è sufficiente mirare sul codice e premere il grilletto. La finestra anteriore proietta una banda luminosa che deve essere centrata sul codice e attraversarlo interamente. Le condizioni ottimali per la lettura si ottengono quando la pistola viene usata con un'inclinazione rispetto al piano su cui si trova il codice, così da evitare il rischio di riflessione diretta, che potrebbe compromettere il risultato della lettura (vedi figura).

La buona lettura è segnalata da un beep sonoro e da uno spot verde che illumina il codice.

Inserendo correttamente la pistola nello stand, questa sarà immediatamente pronta per leggere automaticamente i codici presenti nella sua area di lettura senza premere il grilletto. Inoltre, un puntatore di luce verde verrà attivato per facilitare il posizionamento del codice da leggere, (vedi figura).

La singola lettura di un codice viene garantita dal fatto che una lettura consecutiva dello stesso codice richiede la sua rimozione dell'area di lettura (nessuna decodifica) prima di essere nuovamente accettato dal lettore.

F

Avec les pistolets Heron™, la lecture des codes s'effectue automatiquement et **à distance**. Il suffit de viser le code et d'appuyer sur la gâchette. Le faisceau sortant de la fenêtre de lecture de l'appareil lit le code. Ce faisceau doit être centré sur le code à barres à lire et doit le traverser de part en part.

Pour des prestations optimales inclinez la douchette par rapport au code à lire, afin d'éviter des réflexions directes qui pourraient compromettre la performance de lecture (voir figure ci-dessus).

La lecture correcte est signalée par un beep sonore ainsi que par un spot vert qui illumine le code lu.

Après une introduction correcte du pistolet dans le support, le pistolet est prêt à lire automatiquement les codes qui se trouvent dans la zone de lecture sans appuyer sur la gâchette. Le pistolet déclenche également un pointeur lumineux vert qui facilite le positionnement du code à lire (voir figure).

Une seule lecture du même code est garantie puisque pour lire deux fois le même code, il faut déplacer le code hors de la zone de lecture (aucune lecture) avant qu'il soit lu par le lecteur une deuxième fois.

D

Die Heron™ Lesepistolen lesen Strichcodes automatisch und **berührungslos**. Es genügt auf den Code zu zielen und die Taste zu drücken. Der Code wird mittels eines Lichtbandes gelesen, das das Gerät durch das Lesefenster verlässt. Dieses Lichtband muß den gesamten Code möglichst in der Mitte durchqueren.

Eine optimale Lesung ist gewährleistet, wenn der Benutzer die Pistole bzgl. der Oberfläche, auf der sich der Code befindet, etwas neigt, um eine direkte Reflexion zu vermeiden, wie im Bild oben gezeigt wird.

Das erfolgreiche Lesen wird durch einen "Beeper" und einen grünen Lichtpunkt angezeigt.

Wenn die Pistole im Halter korrekt positioniert wird, ist Sie sofort bereit Codes automatisch (ohne Tastendruck) zu lesen. Außerdem, verlässt die Pistole einen grünen Lichtpunkt, der eine einfache Positionierung des Codes ermöglicht (siehe Bild). Um eine einzige Lesung des Codes zu garantieren, erfordert die Doppellesung den Code vom Lesefenster (kein Dekodierung) zu entfernen. Dann positionieren Sie denselben Code für eine neue Lesung zurück.

E

Los lectores Heron™ capturan automáticamente códigos de barras **a distancia**: sólo hay que encuadrar el código y apretar el gatillo. La lectura se realiza sobre el rayo de luz emitida por la ventana de lectura que debe atravesar el código de parte a parte.

Las condiciones óptimas para la lectura se obtienen inclinando el escáner respecto al código de barras para evitar reflexiones directas de luz que podrían perjudicar el rendimiento de lectura (ver figura arriba). El lector señala una lectura correcta a través de un pitido y de un punto verde.

Insertándolo correctamente en su mostrador, el lector estará listo de forma inmediata para leer automáticamente cualquier código en su área de lectura sin apretar el gatillo. Además, el lector emite siempre una luz verde que facilita el encuadre del código (ver figura arriba). Para evitar que el mismo código sea leído varias veces, para efectuar lecturas consecutivas del mismo código es necesario quitar el código del área de lectura (no decodificación) y volverlo a presentar al lector para que éste lo pueda aceptar otra vez.

TAG DEACTIVATION



UK

The tag deactivation is performed at a distance (a few centimeters). Simply bring the reader closer to the tag. Successful deactivation is signaled by an audible tone (see your EAS System manual).

I

La disattivazione dell'etichetta avviene a distanza (alcuni centimetri). Avvicinare il lettore all'etichetta fino a quando il sistema non emette il segnale di avvenuta disattivazione (consultare il manuale del sistema EAS utilizzato).

F

La désactivation de l'étiquette s'effectue automatiquement et à distance (quelques centimètres). Il suffit d'approcher le lecteur à l'étiquette. La désactivation est signalée par un beep sonore (se réferez au manuel de votre système EAS).

D

Die Deaktivierung des tag erfolgt aus einer Distanz weniger Zentimeter. Das Lesegerät einfach solange an den tag annähern bis ein akustisches Deaktivierungs-Signal ertönt (siehe Handbuch ihres EAS Systems).

E

La desactivación del tag se hace a distancia (a pocos centímetros). Simplemente acerca el lector al tag, y el sistema emitirá una señal sonora indicando que la desactivación se ha realizado correctamente (consultar el manual del sistema EAS utilizado).

STAND INSTALLATION



UK

The stand can be mounted by using self-tapping screws, double sided adhesive strips or rubber feet:

- A) mount the stand directly to the surface using the self-tapping screws;
- B) carefully clean the bottom surface of the stand and the table surface. Remove the protective plastic from one side of the adhesive strips and stick them on the stand bottom. Then, remove the plastic from the other side of the strips and affix the stand to the table;
- C) carefully clean the bottom surface of the stand, remove the protective film from the rubber feet and stick them in the corresponding housing on the bottom surface. It is also possible to fix an optional metal plate.

I

Lo stand può essere montato utilizzando le viti autofilettanti, le strisce adesive oppure i piedini di gomma:

- A) montare lo stand direttamente sulla superficie utilizzando le viti autofilettanti;
- B) pulire accuratamente la superficie inferiore della base dello stand e la superficie d'appoggio. Togliere la plastica protettiva da un lato di ogni striscia e attaccare entrambe le strisce alla base dello stand. Rimuovere la plastica protettiva dall'altro lato delle strisce adesive e attaccare lo stand alla superficie d'appoggio;
- C) pulire accuratamente la superficie inferiore della base dello stand, quindi togliere la pellicola protettiva dai piedini e attaccarli all'interno delle apposite sedi nella base di plastica. Inoltre, è possibile fissare una base metallica opzionale.

F

Pour le montage du support il est possible également d'utiliser des vis filetées, des bandes adhésives ou des petits patins en caoutchouc:

- A) utiliser des vis filetées pour le montage sur la surface d'appui;
- B) nettoyer soigneusement la surface inférieure du support et la surface d'appui. Retirer le plastique protecteur de l'une des faces des bandes et la coller sur la surface inférieure du support. Retirer le plastique protecteur sur l'autre face adhésive et coller le support sur la surface d'appui ;
- C) nettoyer soigneusement la surface inférieure du support. Retirer la pellicule protectrice des patins et coller les patins dans les logements correspondants situés sur la surface inférieure du support. Il est possible aussi de fixer une plaque métallique en option.

D

Der Halter kann mittels der selbstschneidenden Schrauben, der Klebstreifen oder mittels der Gummifüßchen befestigt werden:

- A) für eine permanente Installation verwenden Sie die zwei selbstschneidenden Schrauben.
- B) die untere Seite des Halters und die Ablagefläche sorgfältig reinigen. Die Schutzschicht von einer Seite jedes Klebstreifens entfernen und beide Klebstreifen auf den Halter kleben. Die Schutzschicht von der anderen Seite der Klebstreifen entfernen und den Halter auf der Ablagefläche befestigen.
- C) die untere Seite des Halters und die Ablagefläche sorgfältig reinigen um die Füßchen auf die Sitzen des Halters zu kleben. Man kann auch eine optionale Metallunterlage befestigen.

E

El soporte puede ser montado a través de tornillos auto-bloqueantes (A), tiras adhesivas de doble cara (B) o pies de goma (C):

- A) Montar el soporte directamente sobre la superficie utilizando los tornillos auto-bloqueantes;
- B) Limpiar con cuidado la superficie inferior del soporte y la superficie de la mesa. Quitar el plástico de protección de una de las caras de las tiras adhesivas y pegarla a la superficie inferior del soporte. Luego quitar el plástico de la otra cara de la tira adhesiva y posicionar el soporte en la posición deseada sobre la mesa;
- C) Limpiar con cuidado la superficie inferior del soporte, quitar el plástico de protección de los pies de goma e insertarlos en las posiciones correspondientes en la superficie inferior del soporte. Es posible también fijar una placa de metal opcional.

INSERTION INTO STAND

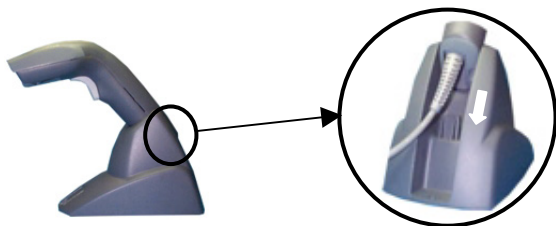

- UK** Pair the reader to the stand paying attention to insert the handle into the stand clip (see figure above). Correct insertion will be signaled by a beep; the reader will then be ready to read barcodes.
- I** Posizionare la pistola nello stand assicurandosi che il manico sia inserito nel fermo dello stand stesso (vedi figura sopra). Un beep sonoro segnalerà il corretto inserimento ed il lettore sarà pronto per leggere i codici a barre.
- F** Placer le pistolet dans le support en faisant attention d'introduire la poignée dans le crochet du support (voir figure ci-dessus). Un beep sonore indiquera un positionnement correct. Le pistolet est ainsi prêt à lire les codes.
- D** Positionieren Sie die Pistole im Halter und stecken Sie den Griff in die Öffnung des Halters (siehe Bild oben). Das korrekte Positionieren wird durch einen Piepton angezeigt. Dann ist die Pistole bereit Codes zu lesen.
- E** Poner el lector en su soporte insertando la empuñadura en el clip del soporte (ver figura arriba). El soporte emitirá un pitido al insertar el lector de forma correcta. El lector estará entonces listo para leer códigos de barras.

EAS CONNECTIONS

NEDAP

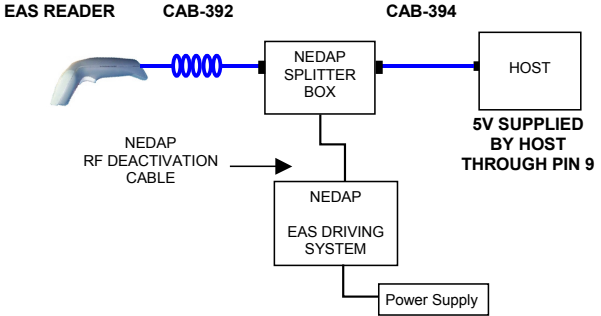

or

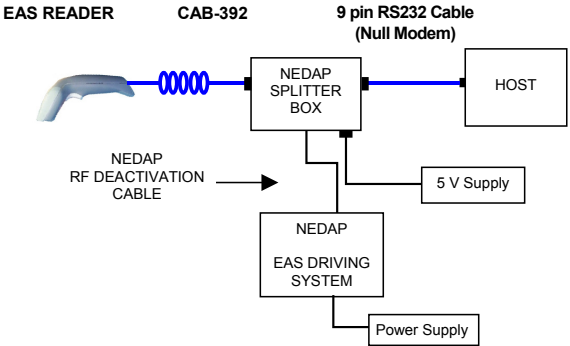

CHECKPOINT

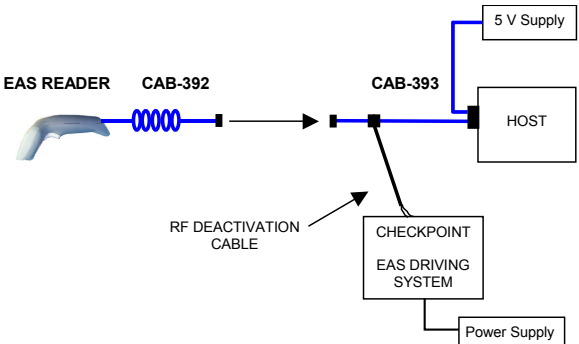

Note: The only valid interface selection is RS232.

ACCESSORIES

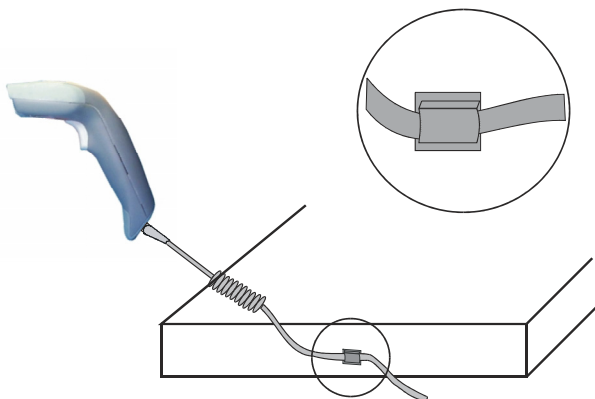

UK

An adhesive cable clamp is provided to fix the cable to a surface.

I

Il fermacavo adesivo fornito consente di fissare il cavo ad una superficie.

F

Le serre-fil adhésive fourni permis de fixer le câble sur la surface voulue.

D

Die klebende Kabelverschraubung erlaubt das Kabel auf die Tischoberfläche zu verschrauben.

E

La brida adhesiva de pared permite fijar el cable en una superficie.

DISCONNECTING THE CABLE

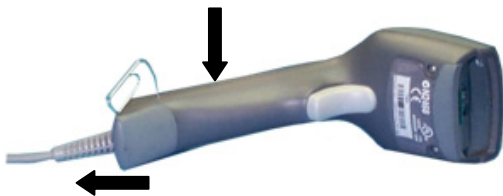

1 DEFAULT

- UK** Read the RESTORE DEFAULT.
- I** Leggere il codice che ripristina i default.
- F** Lecture du code de configuration par défaut.
- D** Lesen Sie den Restore Default Code, um die Werkseinstellung wieder herzustellen.
- E** Lea el código de reastauración predefinida.

RESTORE DEFAULT



RS232 Standard DEFAULT SETTINGS

9600 baud, no parity, 8 data bits, 1 stop bit, no handshaking, delay disabled, rx timeout 5 sec., ack/nack disabled, FIFO enabled;

DATA FORMAT: code identifier disabled, no field adjustment, code length not transmitted, *no header, terminator = CR-LF*, character replacement disabled

RS232 Nixdorf DEFAULT SETTINGS

9600 baud, parity odd, 8 data bits, 1 stop bit, handshaking hardware (RTS/CTS), delay disabled, rx timeout 9.9 sec., ack/nack disabled, FIFO disabled, serial trigger lock disabled;

DATA FORMAT: code identifier enabled, no field adjustment, code length not transmitted, *no header, terminator = CR*, character replacement disabled

RS232 Fujitsu DEFAULT SETTINGS

9600 baud, no parity, 8 data bits, 1 stop bit, no handshaking, delay disabled, rx timeout 2 sec., ack/nack disabled, FIFO enabled, serial trigger lock disabled;

DATA FORMAT: code identifier enabled, no field adjustment, code length not transmitted, *no header, terminator = CR*, character replacement disabled

RS232 ICL DEFAULT SETTINGS

9600 baud, parity even, 8 data bits, 1 stop bit, handshaking RTS always on, delay disabled, rx timeout 9.9 sec., ack/nack disabled, FIFO enabled, serial trigger lock disabled;

DATA FORMAT: code identifier enabled, no field adjustment, code length not transmitted, *no header, terminator = CR*, character replacement disabled

POWER SAVE

scan rate max, standby disabled, sleep disabled

READING PARAMETERS

hardware trigger, trigger active level, no trigger timeout, Flash On = 1 sec, Flash Off = .6 sec, one read per cycle, safety time .5 sec, beeper intensity high, tone 2, beeper type monotone, beeper length short

DECODING PARAMETERS

ink spread enabled, overflow control enabled, interdigit control enabled, Puzzle Solver™ disabled, decoding safety = one read

CODE SELECTION

enabled codes

- EAN 8/EAN 13 / UPC A/UPC E without ADD ON
check digit transmitted, no conversions
- Interleaved 2/5
check digit control and transmission, variable length code; 4-99 characters
- Standard Code 39
no check digit control, variable length code; 1-99 characters
- Code 128
variable length code; 1-99 characters

disabled codes

EAN 128, ISBT128, Code 93, Codabar, pharmaceutical codes, MSI, Plessey, Telepen, Delta IBM, Code 11, Code 16K, Code 49, RSS Codes

ADVANCED FORMATTING PARAMETERS

concatenation disabled, no advanced formats defined

- UK** Read the interface selection code for your application.
- I** Leggere il codice per la selezione dell'interfaccia relativo al modo di comunicazione desiderato.
- F** Lecture du code "Interface" correspondant à votre modèle.
- D** Lesen Sie denjenigen Schnittstellen-Code, der Ihrem gewünschten Kommunikationsmodus entspricht.
- E** Lea el código correspondiente al modo de comunicación deseado.

RESTORE DEFAULT**RS232**

Standard

**POS SYSTEMS**

Nixdorf Mode A



Fujitsu



ICL Mode



UK YOUR READER IS NOW READY TO READ CODES.

To change the defaults refer to the "HHD II Software Configuration Manual", part number **90ACC1877**, or to the DL Sm@rtSet™ Configuration program, both downloadable from the website.

I IL LETTORE È PRONTO PER LEGGERE I CODICI.

Per cambiare le impostazioni di default fare riferimento al manuale "HHD II Software Configuration Manual", n. d'ordine **90ACC1877**, oppure al programma di configurazione DL Sm@rtSet™. Entrambi sono scaricabili dal sito web.

F VOTRE LECTEUR EST PRÊT POUR LA LECTURE DE CODES.

Pour changer les paramètres voir le manuel "HHD II Software Configuration Manual", numéro d'ordre **90ACC1877**, ou bien le programme de configuration DL Sm@rtSet™. Le manuel et le programme peuvent être téléchargés de notre site internet.

D DAS LESEGERÄT IST JETZT BEREIT CODES ZU LESEN.

Um die Werkseinstellungsparameter zu ändern, konsultieren Sie entweder das Handbuch "HHD II Software Configuration Manual", Bestellnummer **90ACC1877**, oder nehmen das Konfigurationsprogramm DL Sm@rtSet™ zu Hilfe. Sie können beide von der Internetseite herunterladen.

E EL LECTOR ESTÁ AHORA LISTO PARA LEER CÓDIGOS.

Para cambiar los parámetros de configuración de fábrica, ver el manual "HHD II Software Configuration Manual", n. de orden **90ACC1877**, o bien el programa de configuración DL Sm@rtSet™. Ambos pueden descargarse de la página web.

TRIGGER SELECTION

After configuring the reader interface type, the software trigger parameter can be selected so that the reader operates like a model without trigger.

Software Trigger



◆ Hardware Trigger



3 OPERATING TEST

UK Read the TEST codes below.

I Leggere i codici di test.

F Lire les codes tests.

D Lesen Sie die Test-Coden.

E Lea los códigos de prueba.

EAN-8



EAN-13



Code 39 (Normal)



Code 128



Interleaved 2 of 5



TECHNICAL FEATURES

Heron™ D150 EAS

Electrical Features	
Power Supply RS232 interface	5 Vdc \pm 5%
Consumption: Maximum Operating Sleep mode	RS232
	180 mA @ 5 Vdc
	150 mA @ 5 Vdc
500 μ A @ 5 Vdc	
Max. Scan Rate	256 scans/sec
Reading Indicators	LED, Good Read Spot, Beeper
Optical Features	
Sensor	CCD solid state (2048 pixels)
Illuminator Wavelength Max. LED Output Power	LED array 630 ~ 670 nm 0.31 mW
LED Safety Class	Class 1 EN 60825-1
Reading Field	see reading diagrams
Max. Resolution	0.10 mm (4 mils)
PCS	min. 15% (Datalogic Test Chart)
Environmental Features	
Working Temperature	0 °C to + 55 °C (+32° to +131 °F)
Storage Temperature	-20 °C to + 70 °C (-4° to +158 °F)
Humidity	90% non condensing
Drop Resistance (on concrete)	IEC 68-2-32 Test ED 1.8 m
ESD Protection	16 KV
Protection Class	IP30
Mechanical Features	
Weight (without cable)	about 170 g. (6 oz.)
Cable Length	1,03 m (3 ft. 4 in.)

READING DIAGRAM

D130 (STD) - Reading Zones (10° skew angle)

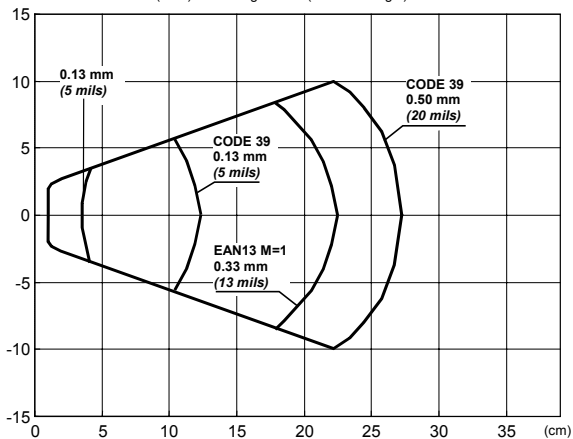

WARRANTY

Datalogic warrants this product against defects in workmanship and materials, for a period of 5 years from the date of shipment, provided that the product is operated under normal and proper conditions.

Datalogic has the faculty to repair or replace the product, these provisions do not prolong the original warranty term.

The warranty does not apply to any product that has been subject to misuse, accidental damage, unauthorized repair or tampering.

SERVICES AND SUPPORT

Datalogic provides several services as well as technical support through its website. Log on to **www.datalogic.com** and click on the links indicated for further information including:

- **PRODUCTS**

Search through the links to arrive at your product page where you can download specific **Manuals** and **Software & Utilities** including:

- **DL Sm@rtSet™** a Windows-based utility program which allows device configuration using a PC. It provides RS232 interface configuration as well as configuration barcode printing.

- **SERVICES & SUPPORT**

- **Datalogic Services** - Warranty Extensions and Maintenance Agreements
- **Authorised Repair Centres**

- **CONTACT US**

E-mail form and listing of Datalogic Subsidiaries

PATENTS

This product is licensed under the U.S. patent:

6,158,661

This product is covered by one or more of the following patents:

U.S. patents 5,992,740; 6,305,606 B1; 6,631,846 B2; 6,517,003 B2; 6,712,271 B2; 6,808,114 B1; 6,817, 525 B2; and 6,834,806 B2

European patents 851,378 B1; 895,175 B1; 962,880 B1; 997,760 B1; 1,128,315 B1; and 1,164,536 B1

Additional patents pending

COMPLIANCE

FCC COMPLIANCE

Modifications or changes to this equipment without the expressed written approval of Datalogic could void the authority to use the equipment.

This device complies with PART 15 of the FCC Rules. Operation is subject to the following two conditions: (1) This device may not cause harmful interference, and (2) this device must accept any interference received, including interference which may cause undesired operation.

This equipment has been tested and found to comply with the limits for a Class A digital device, pursuant to part 15 of the FCC Rules. These limits are designed to provide reasonable protection against harmful interference when the equipment is operated in a commercial environment. This equipment generates, uses, and can radiate radio frequency energy and, if not installed and used in accordance with the instruction manual, may cause harmful interference to radio communications. Operation of this equipment in a residential area is likely to cause harmful interference in which case the user will be required to correct the interference at his own expense.

LED CLASS



LED Classe 1 / LED Klasse 1.

EN60825-1:2001

WEEE COMPLIANCE



dichiara che
declares that the
déclare que le
bescheinigt, daß das Gerät
declare que el

Heron D1XX

e tutti i suoi modelli
and all its models
et tous ses modèles
und seine modelle
y todos sus modelos

sono conformi alle Direttive del Consiglio Europeo sottoelencate:
are in conformity with the requirements of the European Council Directives listed below:
sont conformes aux spécifications des Directives de l'Union Européenne ci-dessous:
den nachstehenden angeführten Direktiven des Europäischen Rats:
cumple con los requisitos de las Directivas del Consejo Europeo, según la lista siguiente:

89/336/EEC EMC Directive	e	92/31/EEC, 93/68/EEC	emendamenti successivi
	and		further amendments
	et		ses successifs amendements
	und		späteren Abänderungen
	y		sucesivas enmiendas

Basate sulle legislazioni degli Stati membri in relazione alla compatibilità elettromagnetica ed alla sicurezza dei prodotti.
On the approximation of the laws of Member States relating to electromagnetic compatibility and product safety.
Basée sur la législation des Etats membres relative à la compatibilité électromagnétique et à la sécurité des produits.
Über die Annäherung der Gesetze der Mitgliedsstaaten in bezug auf elektromagnetische Verträglichkeit und Produktsicherheit entsprechen.
Basado en la aproximación de las leyes de los Países Miembros respecto a la compatibilidad electromagnética y las Medidas de seguridad relativas al producto.

Questa dichiarazione è basata sulla conformità dei prodotti alle norme seguenti:
This declaration is based upon compliance of the products to the following standards:
Cette déclaration repose sur la conformité des produits aux normes suivantes:
Diese Erklärung basiert darauf, daß das Produkt den folgenden Normen entspricht:
Esta declaración se basa en el cumplimiento de los productos con la siguientes normas:

EN 55022 (Class B ITE), August 1994:	LIMITS AND METHODS OF MEASUREMENTS OF RADIO
Amendment A1 (Class B ITE), October 2000:	DISTURBANCE CHARACTERISTICS OF INFORMATION TECHNOLOGY EQUIPMENT
EN 55024, September 1998:	INFORMATION TECHNOLOGY EQUIPMENT. IMMUNITY CHARACTERISTICS. LIMITS AND METHODS OF MEASUREMENTS

Lippo di Calderara, 08/09/2005

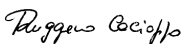
Ruggero Cacioppo
Quality Assurance Laboratory Manager